

Mixer Metos SP-800A-B

230V1~

Easy and stable table-top appliance. 7.6 litre stainless steel bowl

- 3 variable speeds
- bowl protective cover with safety switch, on/off switch
- automatic die-cast aluminium base and column
- white epoxy enamel finish
- a sturdy hand lever on the body column raises and lowers the bowl as well as locking in place at the top and bottom positions.

Standard accessories (included in the offered price):

- stainless steel bowl 7,6 ltr
- stainless steel whip
- aluminium hook
- aluminium beater

Accessories also available for extra cost:

- stainless steel bowl 7,6 ltr
- stainless steel whip
- aluminium hook
- aluminium beater



Mixer Metos SP-800A-B 230V1~

Product capacity	7,6 litres
Item width mm	300
Item depth mm	400
Item height mm	580
Package volume	0.081
Unit of volume	m3
Package volume	0.081 m3
Package length	32
Package width	42
Package height	60
Package unit of dimension	cm
Package dimensions (LxWxH)	32x42x60 cm
Net weight	25
Net weight	25 kg
Gross weight	28
Package weight	28 kg
Unit of weight	kg
Connection power kW	0.2
Connection voltage V	220-240
Number of phases	1PE
Frequency Hz	50
Protection rating (IP)	54
Type of electrical connection	Plug
Sound level dB	64
Power range kW	0.25
Bowl transfer	manual
Attachment drive	No
Timer	No



METOS SPAR

SP502/SP800

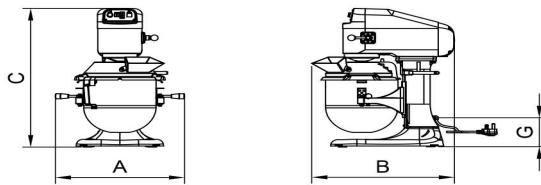

SP-100/SP-200

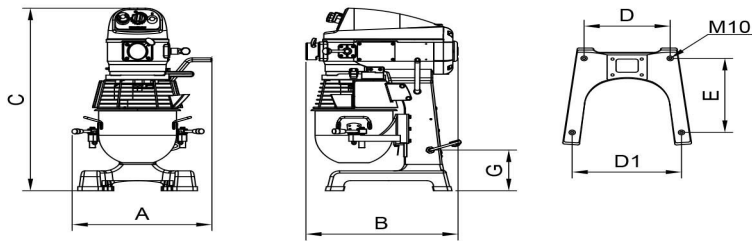

SP-30 - SP80

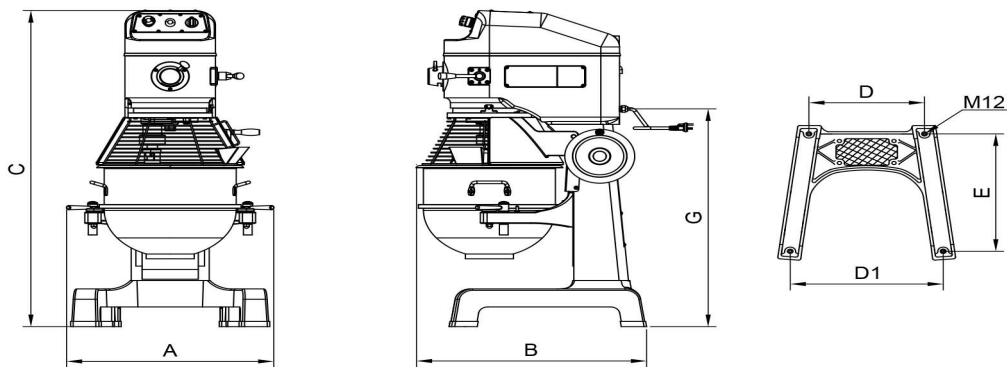

Metos	A	B	C	D	D1	E	G
SP-502A-B	392	388	434	140	136	250	60
SP-800A-B	414	455	580	192	208	282	121
SP-100A	448	490	765	236	301	346	170
SP-200A	550	515	871	242	341	353	217
SP-30HA	650	667	1172	390	496	560	783
SP-40HA	665	738	1315	410	545	575	907
SP-60HA	775	770	1308	410	545	575	899
SP-A80HI	788	1088	1559	440	665	804	1171
SP-B80HI	788	1088	1559	440	665	804	1171