

Water heater Metos WKI 10n 230V1~

All model. Olume 10 l



Water heater Metos WKI 10n 230V1~

Product capacity	30 litres/hour
Item width mm	Ø240
Item depth mm	224
Item height mm	520
Package volume	0.045
Unit of volume	m3
Package volume	0.045 m3
Package length	27.5
Package width	29
Package height	57
Package unit of dimension	cm
Package dimensions (LxWxH)	27.5x29x57 cm
Net weight	10
Net weight	10 kg
Gross weight	11
Package weight	11 kg
Unit of weight	kg
Connection power kW	3.2
Fuse Size A	16
Connection voltage V	230
Number of phases	1N
Frequency Hz	50
Type of electrical connection	Plug
Electrical conn. height mm	20
Remarks (electrical)	P
Cold water diam.	3/4"
Cold water min pressure kPa	200
Cold water conn. height mm	30
Raw material	stainless steel

Water heater Metos WKI 10n 230V1~

Cleaning	hand wash
Temperature area °C	0°C - +97°C
Portion size	10 l



METOS COMBI-LINE

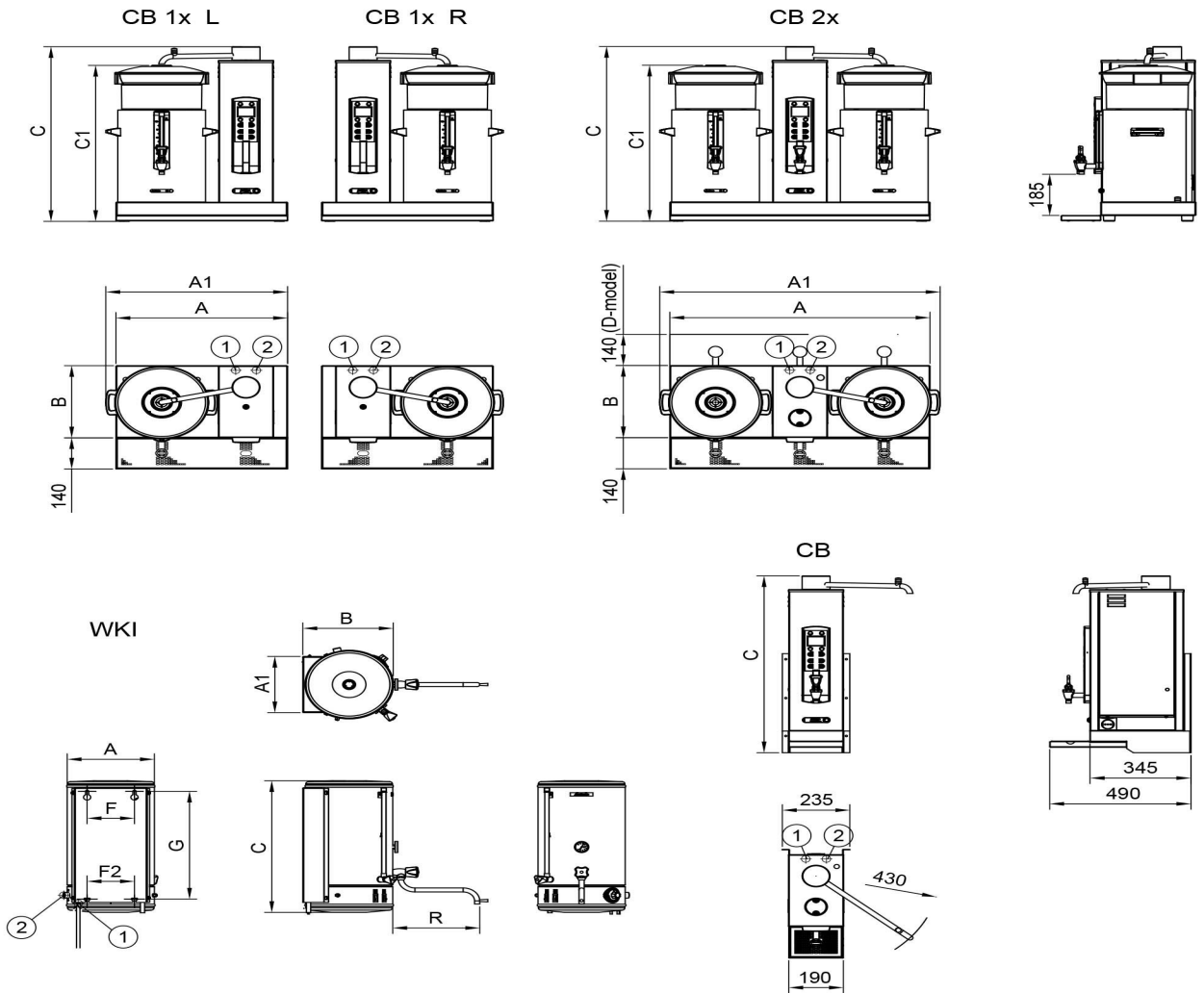

Metos	A	A1	B	C	C1	R	F	F2	G
CB 1 x 5 L/R /W	530		325	692	611				
CB 1 x 10 L/R /W	599	634	325	784	702				
CB 1 x 20 L/R /W	653	693	360	886	803				
CB 2 x 5 /W /D	770	818	325	692	611				
CB 2 x 10 /W /D	907	977	325	784	702				
CB 2 x 20 /W	1015	1095	360	886	808				
WKI 10	Ø224	188	249	523		255	124	74	432
WKI 20	Ø304	253	312	578		303	165	165	484
WKI 40	Ø382	316	404	685		338	165	165	565
WKI 60	Ø382	316	404	856		338	165	165	740
WKI 80	Ø444	367	456	890		338	250	250	780
CB 5 /W				700					
CB 10 /W				800					
CB 20 /W				800					